

Outflow Heater Catalogue 2022



power generation

aggregate coating

whisky distilling

water treatment

space heating

For All Industrial Process Heating Systems

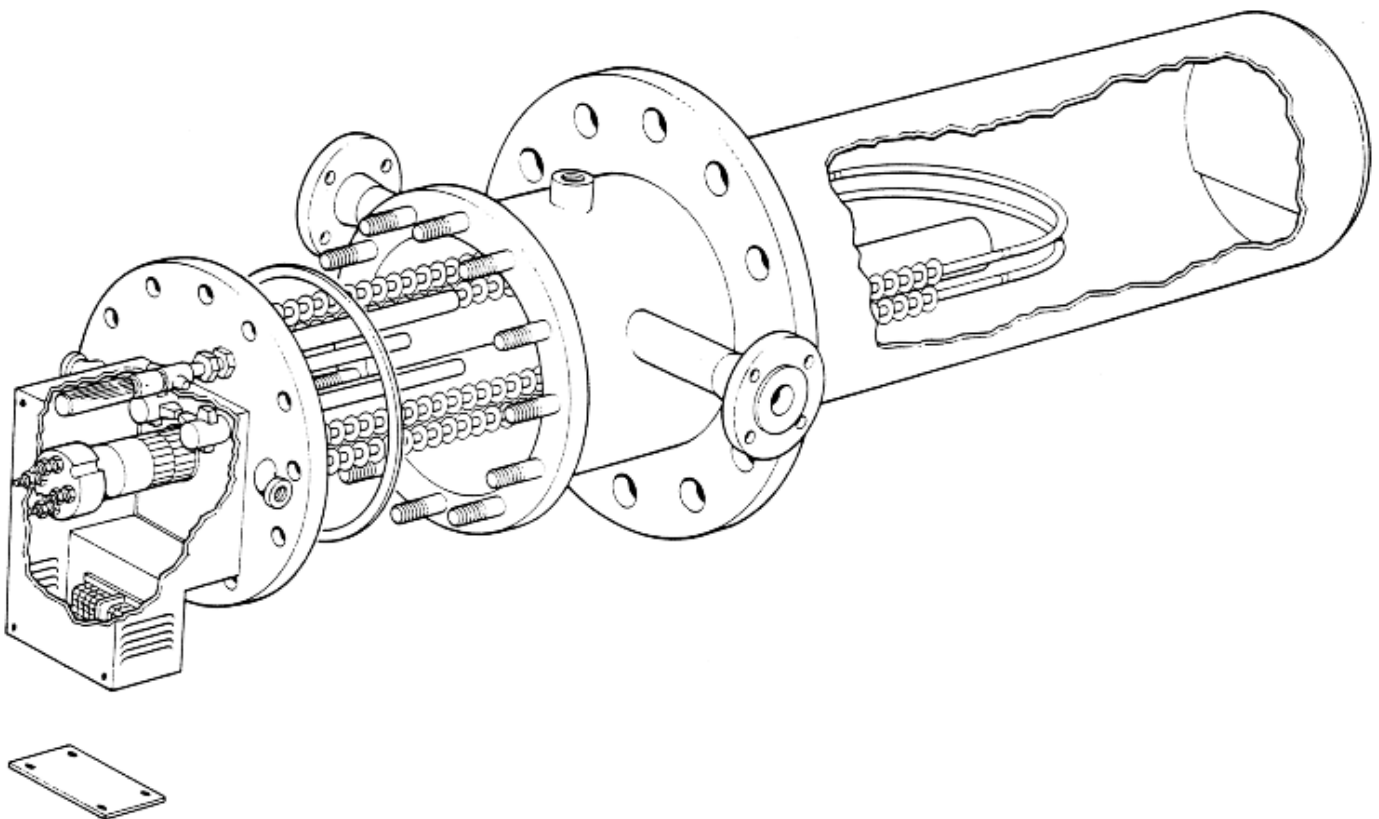

Steam / Electric Outflow Heater for Fuel Oils, Water, Chemicals etc.

Find us on the Internet
At

www.akwaugh.com

274-278 Whitehill Street, Dennistoun, Glasgow G31 3EL, Scotland
tel : +44 141 440 5775 e-mail : sales@akwaugh.com

Index

Page

Foreword		2
Electric Heaters	- OHR Series 6 - 36 kW	3
Electric Heaters	- OEH Series 30 - 144 kW	4
Steam / Electric Heaters	- CSO Series	5
Steam Only Heaters	- CCO Series	6
British Standards	- Information	7
British Standards	- Information	8
Heater Operation	- Information	9

Industrial Process Heating Equipment

Foreword

A.K. Waugh has supplied industry with heating equipment for Oils and for other process fluids for nearly 80 years. Our philosophy is simple - always build equipment that comfortably exceeds the minimum requirements of current standards. The longevity of our equipment is testament to the care with which we apply our experience.

Fuel Oil Heating

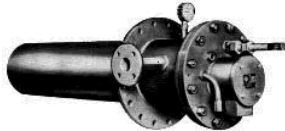

We manufacture Oil Immersion, Oil Outflow and Oil In-Line Heaters. Heaters are individually manufactured to suit your application, and may use several heat sources, the most popular of which is electricity. Use of Steam, Hot Water or Thermal Oil as a primary or additional energy source can be incorporated. (Immersion and In-Line Heaters - see separate catalogues)

Other Fluids

When we are required to manufacture equipment for use with water, acid or alkali this is easily accommodated using different materials than those normally used for oil. Build and testing generally follows the same stringent procedures used for our oil heater products, for the sake of reliability.

Pumping and Heating Units



We provide a complete and integrated Pumping and Heating service. Normally we do not advertise specific systems since most of our equipment is customised in some fashion or other for individual tasks. If this type of equipment is of interest please ask for further information. We will be pleased to help.

Control Panels



We provide a comprehensive range of custom-built panels to suit heaters and P&H sets. These are available with a wide range of options and can be supplied for heater outputs ranging from 3kW to over 350 kW, also manufactured for various climatic zones throughout the world. Detailed specifications are available upon request.

In General

A K Waugh is here to give you technical assistance to let you choose the best heater or combination of heaters for your process. We will give you up to date advice on the fluid you wish to heat, and will work with you towards an effective and efficient solution for your heating needs. Our work is backed up where required by the design and testing services of organisations such as Lloyds Register or DNV. We work to ISO9001:2000 or current update.

Electric Outflow Heaters

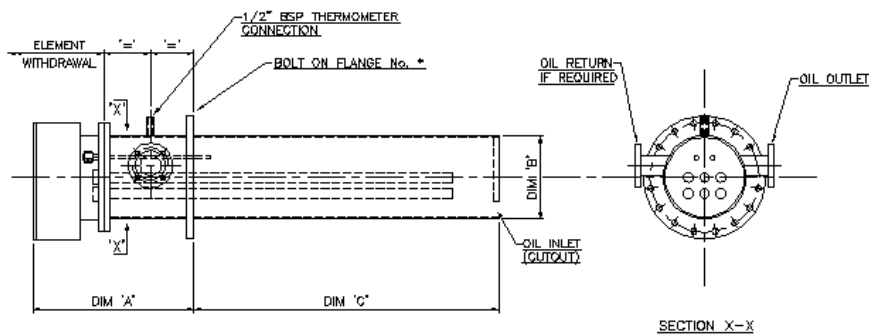

OHR Series for Heavy Oil Output Range 6 - 36 kW

All units have a Watts Rating appropriate to the oil type used
between 6 and 8 W/in² (0.9 and 1.2 W/cm²)

Ratings based on Oil Storage Temperature : 40°C / Oil Outlet Temperature : 55°C
Maximum allowable outlet temperature 100°C

List Number	Rating kW	Litres / hr Raised 15°C	No. & Rating of Elements	Length & Shell O.D.	Mating Flange
OHR 01	6	600	3 @ 2.0 kW	1100 / 250	To suit
OHR 02	9	900	6 @ 1.5 kW	1100 / 250	To suit
OHR 03	12	1200	6 @ 2.0 kW	1100 / 270	To suit
OHR 04	18	1800	6 @ 3.0 kW	1100 / 270	To suit
OHR 05	24	2400	12 @ 2.0 kW	1100 / 320	To suit
OHR 06	30	3000	12 @ 2.5 kW	1100 / 320	To suit
OHR 07	36	3600	12 @ 3.0 kW	1200 / 320	To suit

Higher Kilowatt loadings available on request, built to special Order only.

The outputs shown are the best values obtainable for the particular heater at the stated temperature rise. Other temperature rises can be calculated on a pro-rata basis i.e.

For Fuel Oil, 600 lph @ 6 kW = 15°C rise
Therefore 300 lph @ 6 kW = 30°C rise and so on.

The range above has been rationalised with respect to heating elements, available loadings and body shell / rating combinations. Interchangeability of parts is a major feature and will be useful for those customers with a number of similar heaters on one site. Intermediate loadings will usually be available, but will be treated as non - standard items. In certain units it is possible to divide the load into stages, but only in multiples of 3 elements, to ensure a balanced load.

Standard Equipment : Removable Core type Heating Elements
Controlling and Safety Thermostats as appropriate
Thermometer
Outlet / Return connections to suit.

Extra Items are : Multiple Stage designs (Extra Thermostat(s) & Wiring etc.)
Control Panel
Delivery UK

274-278 Whitehill Street, Dennistoun, Glasgow G31 3EL, Scotland
tel : +44 141 440 5775 e-mail : sales@akwaugh.com

Electric Outflow Heaters

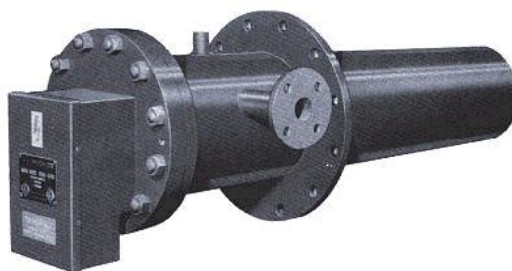

OEH Series for Heavy Oil Output Range 30 - 144 kW

All units have a Watts Rating appropriate to the oil type used
between 4 and 6 W/in² (0.6 and 0.9 W/cm²)

Ratings based on Oil Storage Temperature : 40°C / Oil Outlet Temperature : 55°C
Maximum allowable outlet temperature 100°C

List Number	Rating kW	Litres / hr Raised 15°C	No. & Rating of Elements	Length & Shell O.D.	Mating Flange
OEH 11	30	3000	15 @ 2.0 kW	1000 / 356	To suit
OEH 12	36	3600	15 @ 2.4 kW	1500 / 356	To suit
OEH 13	48	4800	15 @ 3.2 kW	1500 / 356	To suit
OEH 14	60	6000	15 @ 4.0 kW	2000 / 356	To suit
OEH 15	72	7300	18 @ 4.0 kW	2000 / 356	To suit
OEH 16	84	8500	18 @ 4.6 kW	2000 / 406	To suit
OEH 17	96	9700	18 @ 5.3 kW	2500 / 406	To suit
OEH 18	108	10900	18 @ 6.0 kW	2500 / 406	To suit
OEH 19	120	12100	24 @ 5.0 kW	2500 / 460	To suit
OEH 20	144	14600	24 @ 6.0 kW	2500 / 460	To suit

Intermediate or Higher kW loads available on request, built to special Order only.

The outputs shown are the best values obtainable for the particular heater at the stated temperature rise. Other temperature rises can be calculated on a pro-rata basis i.e.

For Fuel Oil, 600 lph @ 6 kW = 15°C rise
Therefore 300 lph @ 6 kW = 30°C rise and so on.

The range above has been rationalised with respect to heating elements, available loadings and body shell / rating combinations. Interchangeability of parts is a major feature and will be useful for those customers with a number of similar heaters on one site. Intermediate loadings will usually be available, but will be treated as non - standard items. In certain units it is possible to divide the load into stages, but only in multiples of 3 elements, to ensure a balanced load.

Standard Equipment : Removable Core type Heating Elements
Controlling and Safety Thermostats as appropriate
Thermometer
Outlet / Return connections to suit.

Extra Items are : Multiple Stage designs (Extra Thermostat(s) & Wiring etc.)
Control Panel
Delivery UK

Steam / Electric Outflow Heaters

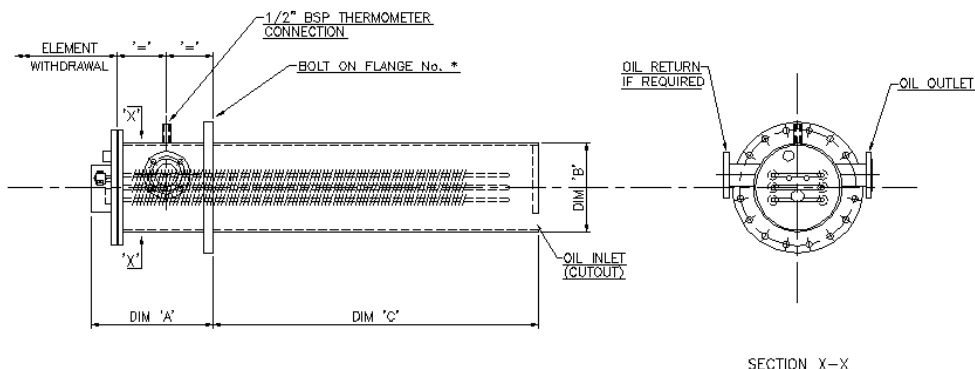

CSO Series for Heavy Oil Output Range 20,000 - 200,000 Btu/hr

All units have a Watts Rating (on electrics) appropriate to the oil type used between 5 and 8 W/in² (0.77 and 1.22 W/cm²)

Steam Pressure 14 bar maximum allowable. All units are sized using 3.4 bar(g) steam
Oil Inlet Temperature : 40°C / Oil Outlet Temperature : 55°C

List Number	Rating kW (30%) (approx)	Litres / hr Raised 15°C	No. & Rating of Elements	Heating Surface Area	Mating Flange
CSO 01	3	800	1 @ 3.0 kW	10 ft ² / 0.9m ²	To suit
CSO 02	6	1600	3 @ 2.0 kW	20 ft ² / 1.9m ²	To suit
CSO 03	9	2500	3 @ 3.0 kW	30 ft ² / 2.8m ²	To suit
CSO 04	9	3300	3 @ 3.0 kW	40 ft ² / 3.7m ²	To suit
CSO 05	12	4200	6 @ 2.0 kW	50 ft ² / 4.6m ²	To suit
CSO 06	15	5000	6 @ 2.5 kW	60 ft ² / 5.6m ²	To suit
CSO 07	18	5900	6 @ 3.0 kW	70 ft ² / 6.5m ²	To suit
CSO 08	18	6700	6 @ 3.0 kW	80 ft ² / 7.4m ²	To suit
CSO 09	24	7600	6 @ 4.0 kW	90 ft ² / 8.4m ²	To suit
CSO 10	24	8500	6 @ 4.0 kW	100 ft ² / 9.3m ²	To suit

*Other Kilowatt loadings / Surface Areas available on request, built to special Order only.
Steam Coil Option available on request.*

The outputs shown are a guide to the values obtainable for the particular heater. We will calculate your requirements and select the heater unit closest to this, with adequate margin.

The range above has been rationalised with respect to heating elements, available loadings and body shell / rating combinations. Interchangeability of parts is a major feature and will be useful for those customers with a number of similar heaters on one site. Intermediate loadings will usually be available, but will be treated as non - standard items.

Standard Equipment : Removable Core type Heating Elements
Controlling and Safety Thermostats as appropriate
Thermometer
Outlet / Return connections to suit.

Extra Items are : Sarco Steam Regulator & Control Valve
Steam Trap Set / Sight glasses etc.
Delivery UK - although this is usually a nominal charge only.

Steam Only Outflow Heaters

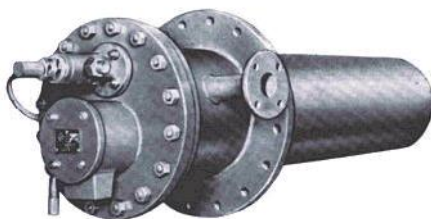

CCO Series for Heavy Oil Output Range 20,000 - 200,000 Btu/hr

Steam Pressure 14 bar maximum allowable

All units sized using 3.4 bar(g) steam

Oil Inlet Temperature : 40°C / Oil Outlet Temperature : 55°C

List Number	Output in BTU's / hr	Litres / hr Raised 15°C	Steam Heating Surface Area	Mating Flange
CCO 01	25,000	800	10 ft ² / 0.9m ²	To suit
CCO 02	50,000	1600	20 ft ² / 1.9m ²	To suit
CCO 03	80,000	2500	30 ft ² / 2.8m ²	To suit
CCO 04	100,000	3300	40 ft ² / 3.7m ²	To suit
CCO 05	130,000	4200	50 ft ² / 4.6m ²	To suit
CCO 06	150,000	5000	60 ft ² / 5.6m ²	To suit
CCO 07	185,000	5900	70 ft ² / 6.5m ²	To suit
CCO 08	210,000	6700	80 ft ² / 7.4m ²	To suit
CCO 09	240,000	7600	90 ft ² / 8.4m ²	To suit
CCO 10	270,000	8600	100 ft ² / 9.3m ²	To suit

Greater Surface Areas / loadings available on request, built to special Order only.

The outputs shown are a guide to the values obtainable for the particular heater. We will calculate your requirements and select the heater unit closest to this, with adequate margin.

The range above has been rationalised with respect to available loadings and body shell / rating combinations. Interchangeability of minor parts is a feature and will be useful for those customers with a number of similar heaters on one site. Intermediate loadings will usually be available, but will be treated as non - standard items.

Standard Equipment : Thermometer
Outlet / Return connections to suit.

Extra Items are : Sarco Steam Regulator & Control Valve
Steam Trap Set / Sight glasses etc.
Delivery UK - although this is usually a nominal charge only.

British Standards & Fuel Oils

The oil heating equipment detailed in this short catalogue conforms and in most cases exceeds the requirements laid down in BS 799 Part 5 and any recent amendments. We have reprinted some of this Standard so that you will be aware of the relevant requirements.

Referring now (briefly) to BS 799 Part 4 - mention is made of materials which are not recommended for use with oil, as follows :

- 1) Copper and some copper alloys are generally unsuitable for coal tar liquid fuels
- 2) Aluminium and aluminium alloys may be unsuitable when in contact with hot fuel.
- 3) Unprotected copper and aluminium and their alloys are unsuitable for
- 4) Metals in contact with oil shall not be galvanized. Unalloyed lead and zinc are unsuitable...

We would respectfully refer you to the following for further information on Industrial Fuel Oils.

B.P. Oil - www.bpamoco.com
Mobil Oil - www.mobil.com
Shell Oil - www.shell.com
Total Oil - www.total.com

You will find their current addresses and contact details in your local telephone directory, or visit their respective Web sites, as above. (information correct at time of printing)

Fuel Oil Storage

British Standards state the normal storage conditions for Oil Fuels. It is our experience, however, that few users actually adhere to the Standards and allow their oil, especially the heavier grades, to go cold. This is not a good idea since fuel oil becomes very viscous at low temperatures. Furthermore, it is very well known that the change of Standard viscosity measurement from Seconds Redwood No. 1 (SR1) to the "Class" system etc, has broadened the band within which a refinery is allowed to produce a certain grade.

For Example : Suppose we have 3500 SR1 oil to hand. Because the grade is directly stated it is reasonable to expect that it will be close to that viscosity or at worst, at some lower viscosity - it should not exceed the stated viscosity. If however we have Class "G" oil, then the viscosity of this may range from, say 3000 SR1 to 4000 SR1, and here lies the potential problem.

Oil producers are already providing oil at the upper limit of the band, namely 4000 SR1, and this oil naturally requires a quite different set of storage conditions than those prevailing at present. For example the Specific Gravity may exceed 1.0 and this means that the oil is heavier than water - which has an impact on storage tank design. Effectively the bottom could rust out of a tank !.

In addition such heavy oil will always require to be kept 'hot' in order to be usable.

British Standards & Fuel Oils**From BS 799 : Part 5 : 1975**

(Note : This supersedes completely the 1962 edition.)

8. Heaters for Oil Storage Tanks

8.1. General - Heaters may be of the following types.

- a) The immersion type inserted through the outlet end of the tank.
- b) The submersion type inserted through the top of the tank.
- c) The outflow type, where the heating elements are concentrated around the outlet.

Details of typical tank heater arrangements are shown in Figure 5. (not available)

The means of heating may be electricity, steam or hot water.

8.2. Electric Heaters.

The electric loading shall not exceed 1.6 W/cm^2 (10 W/in^2) of element sheath surface. Thermostatic control shall be employed; for outflow heaters a safety cut out shall be provided in addition as specified in Part 4 of this standard. Elements and thermostats shall be of the dry type so that they can be withdrawn without emptying the tank. The element sheath or pocket shall be of sufficient strength to prevent damage to the element and shall be supported as necessary along its length by cradles or other supports. Heaters fitted to tanks placed in the open air shall be provided with weatherproof terminal covers.

8.3. Steam and Hot Water Heaters or coils. (Including High Pressure Hot Water Heaters)

These shall be constructed of seamless steel tube and preferably without joints within the tank. Where such joints are unavoidable they shall be welded.

Heaters shall be designed to allow free expansion and shall be supported as necessary along their length by cradles or other supports.

Steam heaters shall be arranged to drain freely and not be subject to water hammer.

Water heaters shall be so designed that any entrapped air is vented automatically.

The maximum temperature of the heating medium shall not exceed 175°C (350°F @150 psi)

8.4. Location.

All heaters and controlling thermostats shall be so located in relation to the draw-off level that their surfaces shall not become exposed.

8.5. Test Conditions.

All parts of the heater subject to internal pressure shall be tested hydraulically at 1.5 times the maximum working pressure or 7 bar gauge, whichever is the greater.

Electric heaters shall be independently earthed.

The insulation resistance between the elements and the heater, when measured at room temperature with a voltage of not less than 500 v.d.c. shall be not less than 1 megohm.

8.6. Marking.

The following information shall be permanently and clearly marked on each heater.

Manufacturers name or trademark and identification mark or serial number

Test pressure and date of test

Maximum working pressure.

On heaters containing electric elements, also : Voltage, Wattage and a diagram of electrical connections where there are more than two terminals exclusive of the earthing terminal.

General Information

Heater Operation

The temperature of the oil exiting the Outflow Heater is controlled by a thermostatic device.

In an electric heater this control is achieved by an electro mechanical thermostat mounted on the tubeplate, with the sensor directly in the path of oil flowing from the heater.

A Control thermostat is set at the oil burning temperature, (or a temperature which equates to that required at the burner end of the pipeline) and the required Safety thermostat is set approximately 20°C higher to compensate for the differentials between the two thermostats. Should the control thermostat fail to operate, the Safety thermostat acts as a master cut-out and switches the heater off. When the fault has been rectified the reset button on the safety thermostat is depressed and the circuit is re-established. While this type of control may be considered unfashionable it is extremely reliable.

For Steam or HPHW heaters a Sarco or Hornes thermostatic regulator and Steam Control valve are incorporated for fully automatic control. Optionally an electronic version of this system is available, however it is often preferable to have the mechanical system since this does not rely on the presence of electrical power. It should be noted that where such heaters are used it is advisable to have the control device situated inside the heater shell in the same manner as for electric thermostats to ensure a steady oil temperature under flow and standby conditions. Where the controls are sited away from the heater, say in a branch pipe, this can give good results under flow conditions, but does not react well to uncontrolled shut-down.

Basic Electronic control via thermocouple and relay is achievable in much the same way as described above except that control differentials are minimised. Thyristor control is also suitable for electric heaters, this mode providing a stepless variation in input load as commanded by a temperature sensor or sensors. We still insist on the provision of a Safety Thermostat for these devices.

Split loads are available on standard controls, generally using heating elements linked in groups of 3 (star connection) to provide a balanced load.

For the purposes of standardisation of outputs, and to smoothly interface with our Line Heater Catalogue, all heaters are shown with an outlet oil temperature of 55°C, the recommended handling temperature for Class G oil.