

A.K. Waugh Limited

Process Heating Engineers since 1940

Heater Installation Instructions

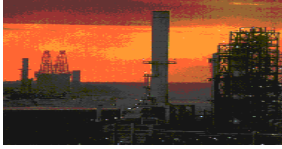

power generation



aggregate coating



whisky distilling



water treatment

For All Industrial Process Heating Systems

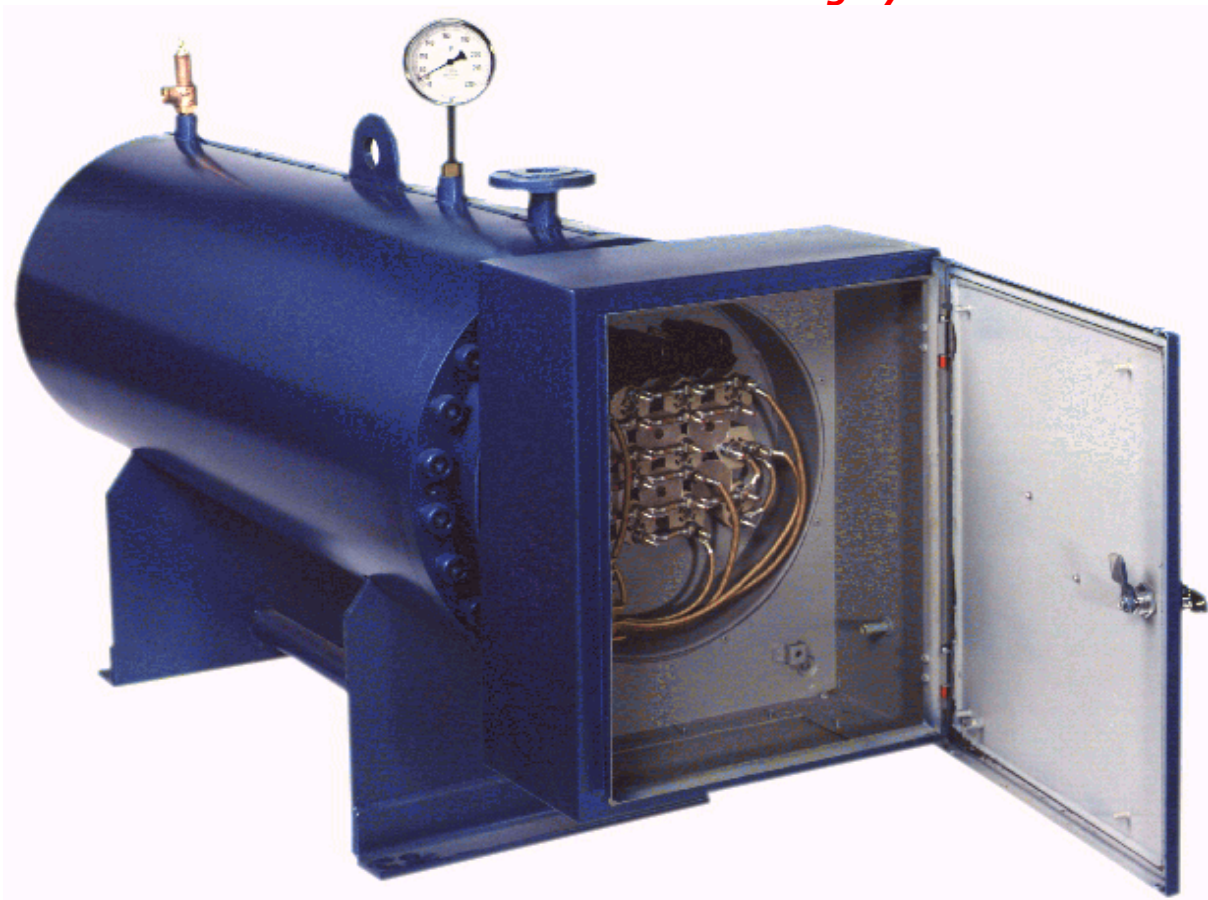

Electric In-Line Heater for Fuel Oils, Water, Chemicals etc.

www.processheaters.co.uk

14, Loanbank Quadrant, Govan, Glasgow G51 3HZ

T : +44 (0)141 440 5775 (Outside UK)

M : 0780 167 6794 (UK)

E : sales@processheaters.co.uk

Installation Instructions for In-Line Heaters with Removable Core Type Elements

Contents

	Page
1.0 : Introduction	3
2.0 : Installation	3
3.0 : Electrical Connections	4
4.0 : Standard Accessories	4
5.0 : Method of Operation of Heater Unit	4
6.0 : Setting of Thermostats	4
6.1 : General Information	
6.2 : Control Thermostats	5
6.3 : Safety (Master) Thermostats	5
7.0 : Maintenance	5
7.1 : Periodic Maintenance	
7.2 : Routine Cleaning - 6 Months	
7.3 : General Overhaul - 12 Months	
8.0 : Spares	6
8.1 : Thermostats	
8.2 : Heating Elements	
8.3 : Relief Valve	
9.0 : Fault Correction	6
9.1 : Poor Control Characteristics	
9.2 : Required Outlet Temperature Unobtainable	
9.3 : Constant Fuse Failure	
9.4 : Safety (Master) Thermostat Trip-Out	7
9.5 : Spares Ordering Information	7
9.6 : Thermostat Data	8

1.0 Introduction

AKW series LHR and EHL Line heaters are basically designed for oil preheating applications. The construction of the heater unit is mild steel throughout using materials conforming with British Standard Specifications. Where a fluid other than oil is to be heated then material specifications vary accordingly. The heater design follows conventional layout with separable Tube Plate and Heater Shell thus enabling the heating battery to be removed easily for repair, replacement or upgrading.

The tube bundle is optimally designed for the use which is specified in the original Order, and may be baffled to optimise heat transfer rates without exceeding pressure drop limitations.

The basic heater unit solely comprises the tube bundle with a header assembly fitted to a fully insulated and clad pressure vessel. This allows for flexibility of design in that heaters for horizontal and vertical fixing or heaters with various types of oil temperature control systems all utilise the basic heater unit and all design alterations necessary for particular systems are confined to external fittings. In general therefore this Instruction Manual is confined to the basic heater unit and where applicable literature is appended dealing with the various accessories supplied.

2.0 Installation

LHR and EHL heaters are mounted either horizontally or vertically according to the clients wishes. Definite instruction must be given to supply vertical mounted types otherwise a horizontal unit will be supplied. Design changes are necessary for the vertical type, such as change over of the normal inlet and outlet connections and a modification to the control unit housing. Control housings are normally fitted with either left or right handed accessory fittings, e.g. thermometer etc., dependant upon instructions.

The following connections are provided as standard :

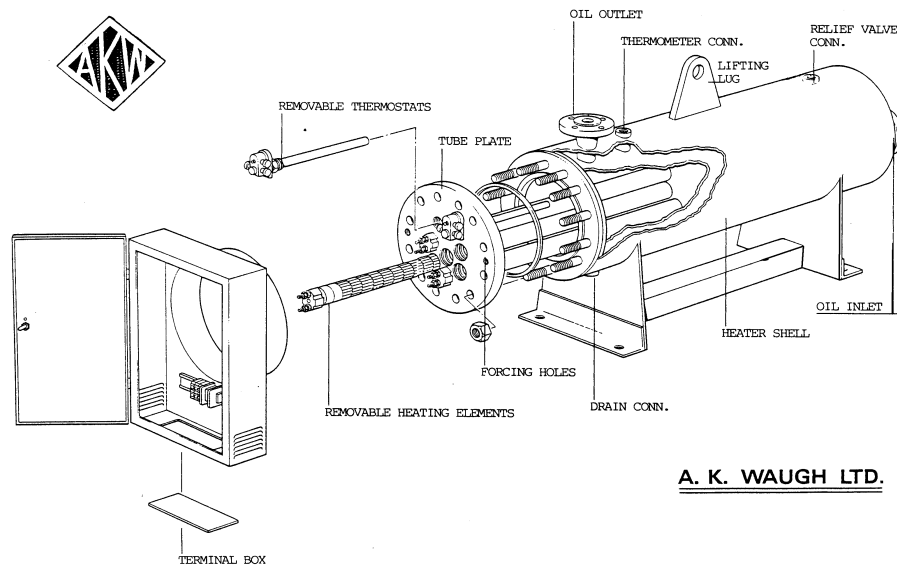

- 1) Oil Return / Inlet
- 2) Oil Flow / Outlet
- 3) Oil Drain
- 4) Thermometer
- 5) Thermostats
- 6) Relief Valve

Care must be taken to ensure that sufficient free space is provided for the withdrawal of either the heating element(s) or the tube bundle. This withdrawal length is usually given on the heater drawing, or can be assumed to be the length of the heater shell. Entire heaters can be lifted by connecting suitable gear to the lifting lugs or to the flange and end plate holes.

It is recommended that horizontal heaters are mounted to give a tilt towards the header assembly or drain, wherever it is placed. This ensures that sludge will collect and drain correctly. A tilt of 1" in 5' (25mm in 1500mm) is considered satisfactory.

3.0 Electrical Connections

Conduit bosses or a detachable plate for drilling on site are provided at the base of the terminal box, although in some cases adequate space can be found on the side or, where appropriate, circumference, of the enclosure for the Plant Engineer to add additional conduit connections if required.

Since all electromechanical thermostats are single phase devices and of 15 Amp (A.C.) maximum rating, direct connection to the electrical supply is limited to 3.0 kW single phase, 220 / 250 volts (A.C.) Current loads in excess of 15 Amps (A.C.) and all three phase and D.C. supplies necessitate the use of a separate contactor for each electrical heating stage.

The coil circuit of the contactor is normally wired in series with the master thermostat / control thermostat and, when specified, a hand operated switch. It is important that for multi-stage heaters, the control thermostats are connected to the coil of the corresponding contactor, as shown on the wiring diagram.

4.0 Standard Accessories

We usually supply a relief valve to suit the stated working pressure, which fits in a 1/2" or 3/4" BSP connection. Normally we also supply a thermometer, which is provided with a 1/2" BSP mild steel (or other material as appropriate) pocket so that the instrument may be removed without draining the heater or interrupting the process. A spare oil joint can be supplied on request. These items are supplied "loose" and will normally be found in a box attached to the newly delivered unit, or will be contained in the locked terminal box.

5.0 Method of Operation of the Heater Unit

This type of heater works by transferring electrically generated heat to a liquid.

The performance of this type of heater has been evaluated and a distinct calculation is undertaken for each application. In addition, the operational characteristics have been moulded by over 50 years of experience in designing for robustness and efficiency.

Heat is transferred to the liquid by means of removable ceramic formed heating elements or cores, fitted into a sheath or tube. The rate of heat output is closely related to the type of fluid being heated. Various data is available both in British Standards and fluid supplier literature for guidance. We always work in advance of upcoming standards where this is deemed to be to the benefit of the life of the equipment.

Control and Safety thermostats are standard features. All thermostats are normally closed (ON) so that an increase in liquid temperature above the (adjustable) set temperature opens the thermostat contacts and therefore the heater circuit is switched OFF. All thermostats are of the changeover type, that is the thermostat switches from one contact to another. Please see the relevant documentation. The inclusion of this feature gives the option of warning or operation indication. This is especially relevant in the case of the Safety thermostat, which must be manually reset.

Control is achieved by a temperature measurement device or devices which may take the form of adjustable electromechanical thermostats as previously described, or electronic thermostats normally utilising a simple probe linked to a sophisticated control device.

In every case we can provide fittings suitable for a variety of devices.

We always fit a Safety (master cut-out) thermostat as standard in compliance with British Standards, regardless of the apparent safety features claimed for other devices.

6.0 Setting of Thermostats

6.1 General Information

Thermostats fitted have adjustable scales covering the temperature control range required. Each thermostat is fitted in a pocket which enables replacement without draining down the vessel contents.

If more than one control thermostat is fitted, it will generally be sited above a heating element corresponding to the particular control group.

Note that in most cases the thermostat senses a higher temperature than the actual liquid temperature since it is in the direct path of hot liquid rising from the element sheaths, hence there is a differential between the actual outlet temperature and that to which the thermostat should be set. So in the case of the heater we would see that the thermostat should be set at a higher temperature, say 100 degrees, so as to provide an outlet temperature of 90 degrees.

The differential is - in this example only - 10 degrees. As always, some trial and error is necessary to establish the correct setting to compensate for the measurement errors which abound in normal process plant.

6.2 Control Thermostats

A Control Thermostat is normally fitted to the heater, and this may control any chosen load via a suitable control panel. Practically however this is usually limited to around 40 kW, with a heater of larger capacity being split into two or more heating sections

In multi-stage units the number of Control thermostats varies according to the number of stages. The minimum number of heating elements to each Control thermostat is three.

Where more than one Control thermostat is fitted, they should be set at different temperatures so that a base load is "ON" for longer than the makeup load which operates "ON/OFF". In every case, the control system should be set up in ascending load order.

6.3 Safety (Master) Thermostats

One Master thermostat is supplied with each heater to protect the unit from excessive liquid temperature when a fault arises. The thermostat is usually set some 25 degrees C above the liquid outlet temperature or other recommended temperature. When this temperature is exceeded the master thermostat opens all the heater circuits thus closing down the system.

In some cases the master thermostat is wired in series with the liquid transfer pump electrical system. As a matter of good practice this should incorporate a means whereby the pump continues to operate for a short period of time (say, five minutes) to ensure that the liquid in the heater does not overheat due to residual heat build up.

If the thermostat trips, it will be necessary to manually reset it since it will not automatically close as the temperature falls.

NOTE : It is extremely important that the mains supply is isolated before attempting to reset the Master thermostat since the operator may be unaware of energising the heater elements as soon as the thermostat is reset.

7.0 Maintenance

The best way to enjoy a long and trouble free life from any piece of equipment is to keep it well maintained. We recommend that maintenance be carried out at least once per year and a close check kept on sludge removal etc., so that a schedule which is efficient and effective for your application may be established.

7.1 Periodic Maintenance

- (a) Ensure all electrical connections are clean, dry and tight.
- (b) Check for liquid leakage around the tube plate to heater ring flange joint.
- (c) Ensure that the heater is isolated from the fluid transfer system, and that it is cool. Loosen drain valve and check for sludge build up. If this is excessive then remove the air vent if it is a vertical unit or remove the relief valve if it is a horizontal unit - remember there may be pressure in the system despite being isolated.

NOTE : Never attempt to open a hot heater unit.

7.2 Routine Cleaning - 6 monthly if required.

- (a) Isolate the heater and drain the contents
- (b) Disconnect all accessories and check for damage or corrosion. Refer to separate manuals where applicable for maintenance details.

7.3 General Overhaul - 12 monthly at least.

- (a) Carry out Routine Cleaning schedule and
- (b) Ease out tube plate by means of set screws in forcing holes provided.
- (c) Remove heater battery from shell and inspect element tubes for scale and corrosion.
- (d) Remove scale carefully by wire brushing.
- (e) Inspect heater shell where visible and clean where necessary.
- (f) Re-fit heater battery - using a new gasket - and re-fit other accessories, heating elements, thermostats etc. in reverse order to above.
- (g) Re-fill system, ensuring all air has been expelled.
- (h) If possible, pressure test to rated pressure on nameplate, or to available pressure on site.

NOTE : DO NOT ATTEMPT TO SWITCH HEATER ON UNTIL ALL AIR HAS BEEN VENTED AND FLUID FLOW HAS BEEN ACHIEVED (THUS CONFIRMING ALL VALVES ARE OPEN). FAILURE TO OBSERVE THIS CAUTION MAY RESULT IN EXPLOSION. DO NOT TAKE SHORT CUTS WITH SAFETY.

8.0 Spares

8.1 Thermostats

If a thermostat is faulty in any way it must be returned to our works for inspection. Thermostats can be easily removed by releasing the electrical connections and pinching screws.

Standard thermostats are available from stock but others may be several weeks delivery. Since we do not manufacture these items ourselves, it is sometimes difficult to estimate delivery.

A list of Standard items is given at the end of this booklet.

When a spare thermostat is required, ALWAYS give us the details on the nameplate of the heater.

8.2 Heating Elements

Replacement Heating Elements are available from our factory provided that full details are given, as shown on the last page. The Serial Number is vitally important.

Heating elements can be removed easily by loosening the retaining clip screws. If difficulty is experienced beyond that which you might consider normal, bearing in mind that these elements should be a sliding fit in their sheaths, then it is imperative that you telephone us directly for advice. If you fail to do so, we cannot be held responsible for any breakages.

Note that occasionally some small ceramic parts may be left within the element sheath. You should check the removed element for missing parts and ensure that the sheath is clear of obstruction to allow element replacement.

In general, heating elements are warranted in the same way as the heater unit i.e. A one year warranty exists. However as these items are the subject of differing operating regimes the application of any warranty is at our sole discretion.

8.2 Relief Valve

Oil pressure relief valves are provided for intermittent discharge only and are not sized for full discharge on the larger heaters. Spare valves can be had on early delivery. Please quote all the necessary details when ordering. It would be very helpful if you could determine the pressure, which is stamped on the "hex" of the valve, and the fitting size, since this information will normally confirm ours so that you receive the right item.

9.0 Fault Correction

9.1 Poor Control Characteristics

Reset the thermostats and if it is felt necessary check operation by immersion in a fluid of known temperature. A kettle full of boiling water is sufficient for testing. Where it is felt that the temperature indicated on the thermostat scale does not accord with that of the test, we recommend that you return the item for replacement.

9.2 Required Outlet Temperature Unobtainable

This can be due to the failure of one or more heating elements and a resistance test should be carried out on the suspect items. If a fault is found, then refer to Spares Ordering for details of how to order a new element.

If a fault cannot be readily found within the heater, then check other parts of the system BEFORE suspecting anything else. Once you are satisfied that the problem lies with the heater unit, begin a logical fault finding process as outlined on the appropriate page .

9.3 Constant Fuse Failure

Check earth insulation and phase/phase insulation of heater unit.

Resistance readings should be better than 1 Megohm. when cold. However if the heater has been in a damp environment for some time, it is possible that the ceramic heating cores are also damp, thus giving poor insulation values. Rectify by removing cores and drying in a warm oven or by carefully applying a low voltage supply to the elements.

9.4 Safety (Master) Thermostat Trips out

Before manually resetting the Safety thermostat, carefully check the cause of the trip. This could be any of the following :

- a) Setting is too low - set at least 25 C above normal working temperature
- b) The Control thermostat or thermostats have failed in the closed circuit mode (ON)
- c) If the thermostat continually trips regardless of setting, suspect failure of the thermostat unit itself and you should replace the item. Note that thermostat failure due to faulty manufacture is extremely rare and warranty claims will be on the basis of payment for replacements followed by refund where appropriate.
- d) If this is accompanied by a difficulty in removing heating elements, you must contact this office immediately for further guidance. See Waste Oil Notes.

9.5 SPARES ORDERING INFORMATION

It is essential when ordering spares to quote all the details given on the nameplate.
These comprise :

SERIAL NUMBER

DATE

KILOWATT RATING

(Optionally - Original purchaser)

The important detail is the Serial Number. Failing that we would need a name and date.
We maintain records spanning our entire existence - over 50 years - but we still need something to go on if we are to provide good service.

9.6 Thermostats - Standard Issue Listing

ACS Thermostats - 3 Contact, Changeover Switch.

Catalogue No. Stem Length Stem Diameter Range ACS/C3717 in3/8"0 - 150 CACS/C313*11 in3/8"0 - 150
CACS/C31511 in3/8"0 - 100 CACS/C31611 in3/8"20 - 120 CACS/C31711 in3/8"50 - 150 CACS/C380*18 in3/8"0 -
100 CACS/C381*18 in3/8"20 - 120 CACS/C382*18 in3/8"50 - 150 CACS/C38518 in3/8"0 - 60 C

For variations on the above range, modify the Catalogue No. as follows :

For Safety (Master) Thermostats, substitute ACS/Cxxx with ACS/Exxx

For 5/16" diameter stem series, substitute ACS/C3xx with ACS/C5xx

Note that items marked * are not available in 5/16" diameter

The list above is not exhaustive and you may find that you have different items from those quoted, especially in older heater units. Please be especially aware that the Fahrenheit range has to all intents and purposes been abandoned in favour of the Celsius or Centigrade range.